

# MANUAL FLUSH BOLTS

## 2987 SERIES

SUBSTRATE: ZINC

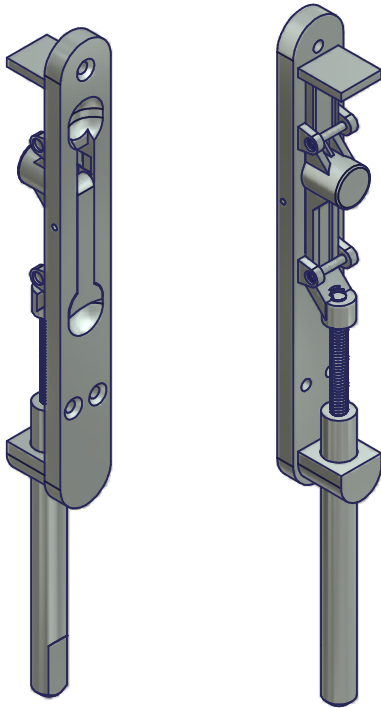

FRONT

BACK

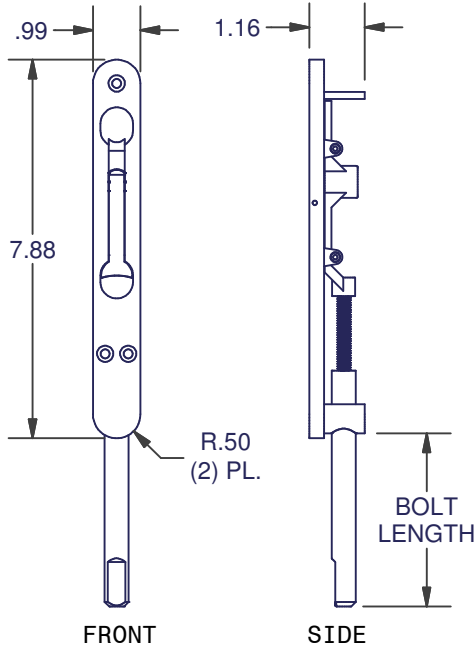

FRONT

SIDE

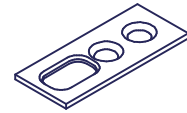

WORKS WITH 3087  
STRIKE PLATE

FINISH	BOLT LENGTH (.500 DIA.)	
	1.781	4.906
BRASS	2987-2-1043	2987-5-1043

## 6351 SERIES

SUBSTRATE: ZINC

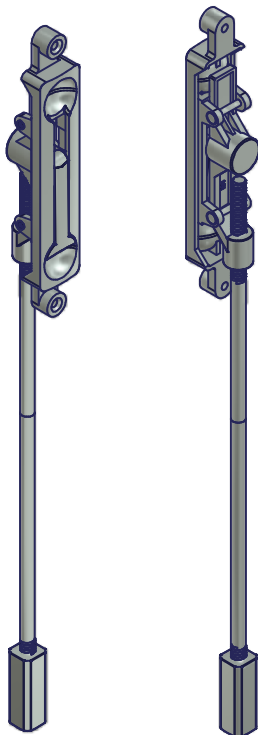

FRONT

BACK

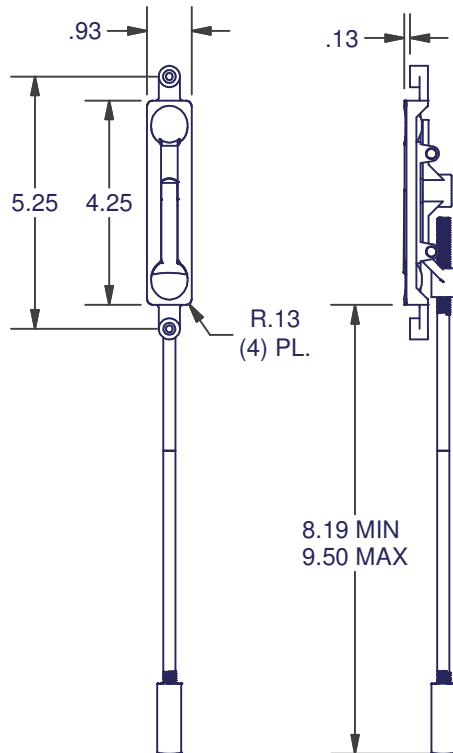

FRONT

SIDE

8.19 MIN  
9.50 MAX

ITEM	FINISH
6351-125-SW-1	WHITE

DIMENSIONS ARE FOR REFERENCE ONLY AND ARE IN INCHES UNLESS OTHERWISE NOTED.  
CONTACT OUR ENGINEERING DEPARTMENT WITH SPECIFIC APPLICATION QUESTIONS OR REQUIREMENTS.  
NOT ALL COMBINATIONS LISTED ARE CURRENTLY STOCKED, EXTRA LEAD TIME MAY BE REQUIRED.