

MISC. SLIDING DOOR

PANEL BRACKETS
2490 SERIES
 MATERIAL: ALUMINUM

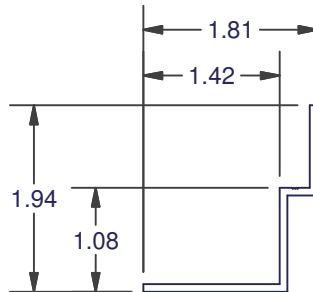
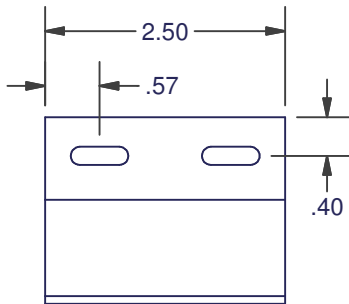
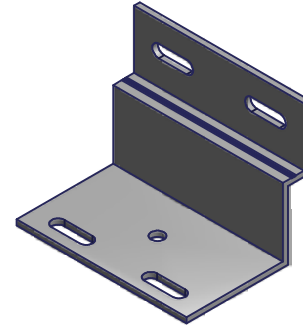
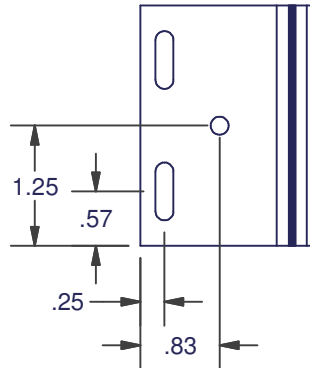

COLOR	ITEM NUMBER
WHITE	2490-10MW

2502 SERIES
 MATERIAL: ALUMINUM

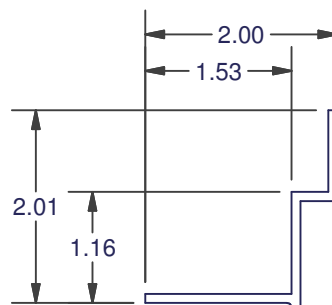
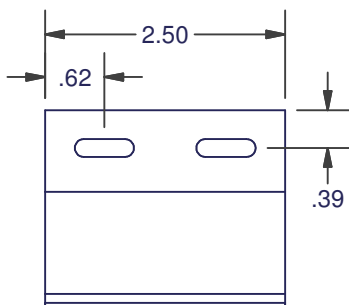
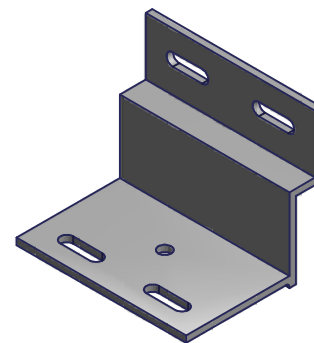

COLOR	ITEM NUMBER
ALMOND	2502-10MA
WHITE	2502-10MW

DIMENSIONS ARE FOR REFERENCE ONLY AND ARE IN INCHES UNLESS OTHERWISE NOTED.
 CONTACT OUR ENGINEERING DEPARTMENT WITH SPECIFIC APPLICATION QUESTIONS OR REQUIREMENTS.
 NOT ALL COMBINATIONS LISTED ARE CURRENTLY STOCKED, EXTRA LEAD TIME MAY BE REQUIRED.