

ACCESSORIES

KEEPER

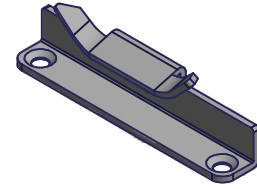
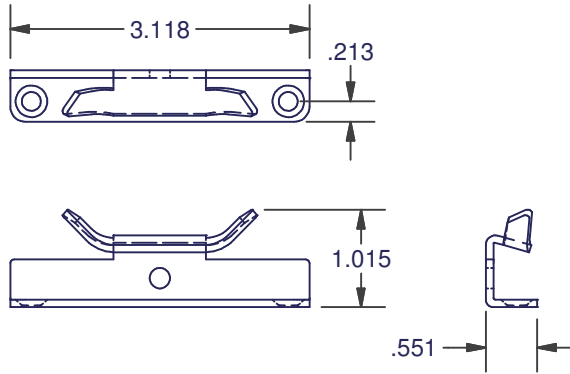

16-003-0-01-301 NON HANDED

KEEPER

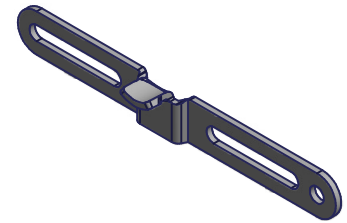
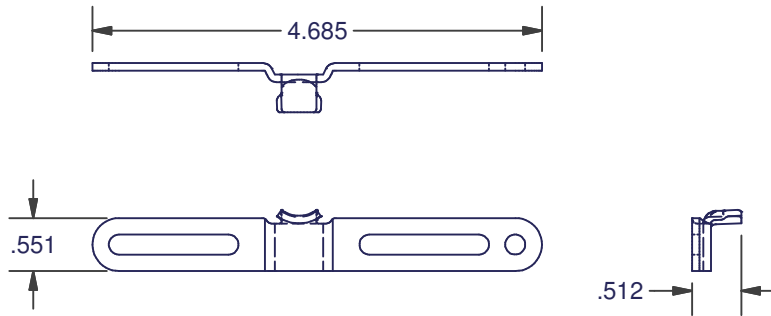

16-002-1-01-301 LEFT HAND SHOWN
16-002-2-01-301 MIRROR IMAGE

KEEPER

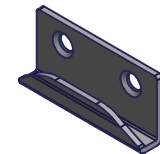
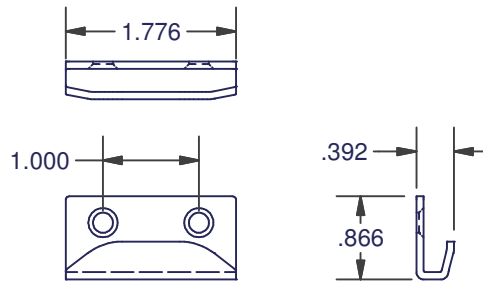

16-001-0-01-301 NON HANDED

FOAM GASKET

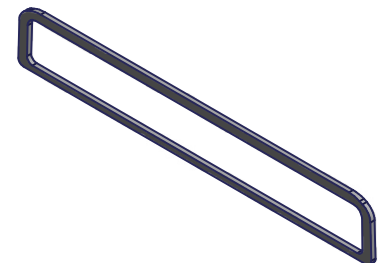
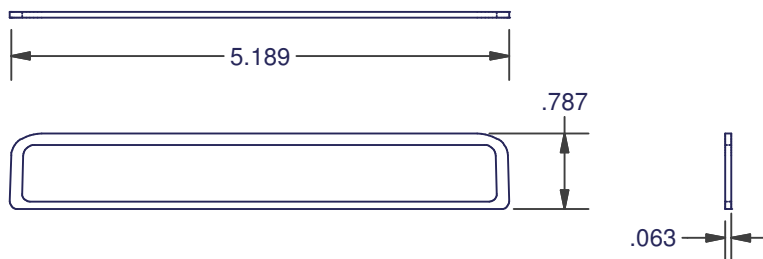

DIMENSIONS ARE FOR REFERENCE ONLY AND ARE IN INCHES UNLESS OTHERWISE NOTED.
CONTACT OUR ENGINEERING DEPARTMENT WITH SPECIFIC APPLICATION QUESTIONS OR REQUIREMENTS.
NOT ALL COMBINATIONS LISTED ARE CURRENTLY STOCKED, EXTRA LEAD TIME MAY BE REQUIRED.